



SOLLEVATORE A CASSETTO

CASSETTE UNDERFLOOR LIFT



mod. SCM 860

DATI TECNICI TECHNICAL FEATURES

PORTATA MAX MAXIMUM CAPACITY	300 Kg
PESO WEIGHT	130 Kg
PIATTAFORMA IN ALLUMINIO ALUMINIUM PLATFORM	1140x800 mm
ALIMENTAZIONE POWER	12 V
ALTEZZA MASSIMA ELEVABILE MAX LIFTING HEIGHT	1000 mm.

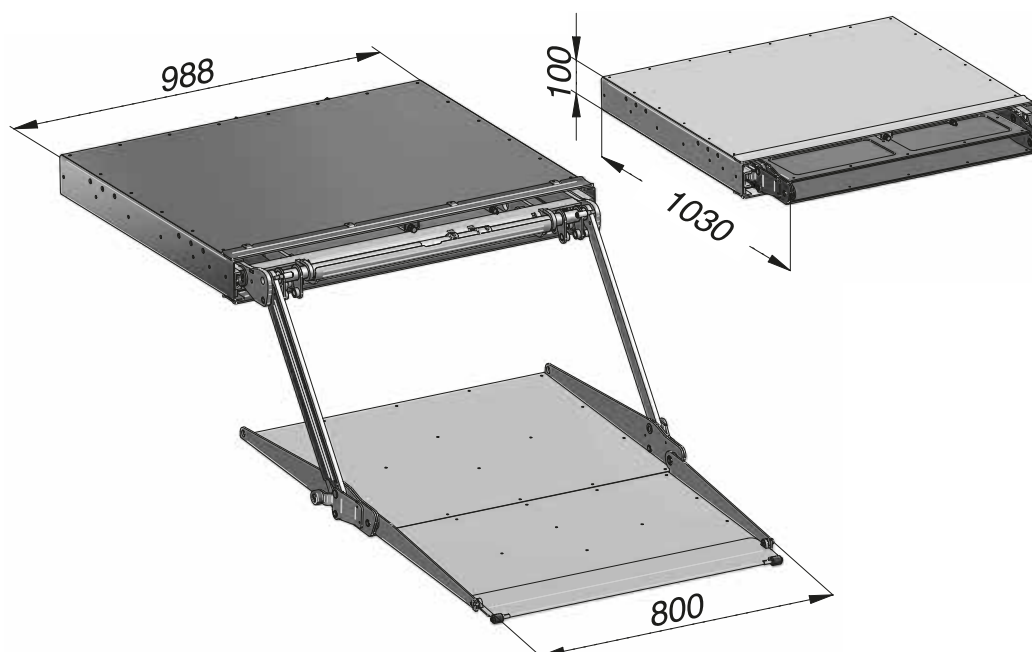
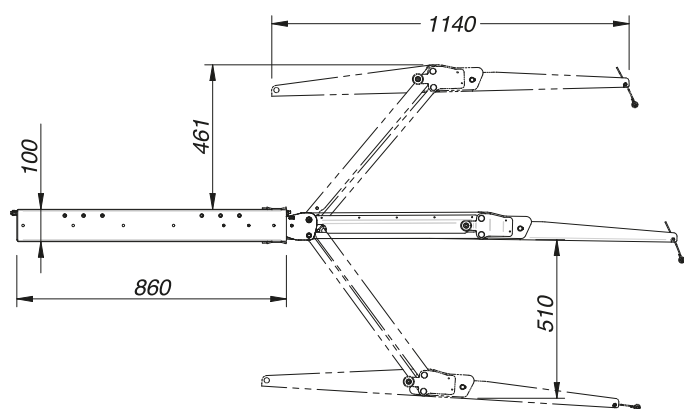

DISPOSITIVI DI SICUREZZA SAFETY DEVICES

- Cassetto aperto posteriormente con gradino d'accesso al piano del veicolo.
Rear opened housing with vehicle floor access step.
- Piattaforma antiscivolo in due pezzi con apertura manuale.
Antislip aluminium platform in two segments to be opened manually.
- Ribaltina di raccordo a terra automatica.
Automatic ground connecting flap.
- **Optional:** ribaltina di raccordo al veicolo.
Optional: floor vehicle connecting flap.
- Centralina elettroidraulica "made in Italy" provvista di pompa ausiliaria di emergenza.
Electro-hydraulic box "made in Italy" with auxiliary emergency pump.
- Motoriduttore elettrico per fuoriuscita pedana con sistema manuale di emergenza.
Geared motor to control the platform sliding and manual emergency system.
- Comandi elettrici su pulsantiera a cavo spiralato.
Spiral cabled remote control.
- Cassetto in acciaio inox.
Stainless steel housing.

DIMENSIONS/INGOMBRI SCM 860