



SOLLEVATORE A CASSETTO

CASSETTE UNDERFLOOR LIFT



mod. SCM 1090

DATI TECNICI TECHNICAL FEATURES

| | |
|---|-------------|
| PORTATA MAX MAXIMUM CAPACITY | 300 Kg |
| PESO WEIGHT | 130 Kg |
| PIATTAFORMA IN ALLUMINIO ALUMINIUM PLATFORM | 1140x800 mm |
| ALIMENTAZIONE POWER | 12 V |
| ALTEZZA MASSIMA ELEVABILE MAX LIFTING HEIGHT | 1000 mm. |

DISPOSITIVI DI SICUREZZA SAFETY DEVICES

- Cassetto chiuso posteriormente con coperchio automatico.
Rear closed housing with automatic cover
- Piattaforma antiscivolo in due pezzi con apertura manuale.
Antislip aluminium platform in two segments to be opened manually.
- Ribaltine di raccordo a terra e al piano del veicolo automatiche.
Automatic ground and floor connecting flaps.
- Centralina elettroidraulica "made in Italy" provvista di pompa ausiliaria di emergenza.
Electro-hydraulic box "made in Italy" with auxiliary emergency pump.
- Motoriduttore elettrico per fuoriuscita pedana con sistema manuale di emergenza.
Geared motor to control the platform sliding and manual emergency system.
- Comandi elettrici su pulsantiera a cavo spiralato.
Spiral cabled remote control.
- Cassetto in acciaio inox.
Stainless steel housing.

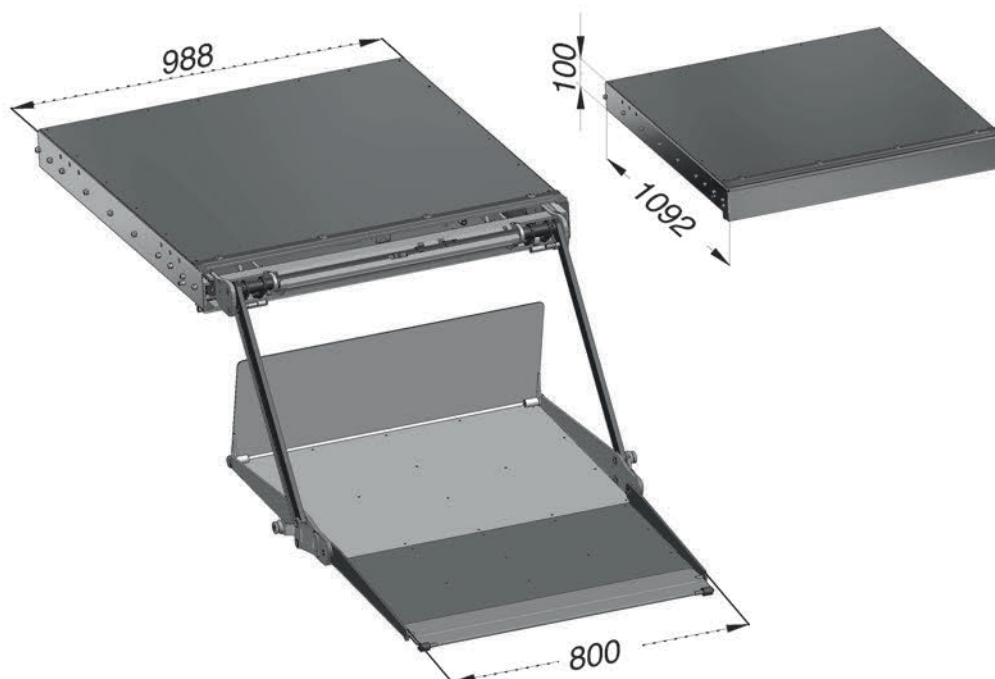
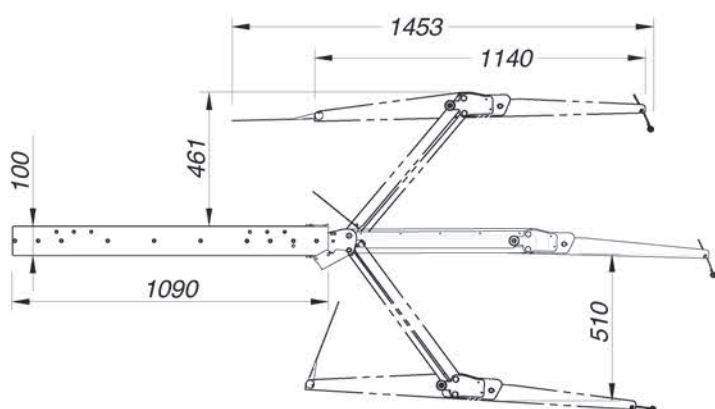

DIMENSIONS/INGOMBRI SCM 1090