



LIFT BBO



140.90

DATI TECNICI TECHNICAL FEATURES

PORTATA MAX MAXIMUM CAPACITY	360 Kg
PESO WEIGHT	140 Kg
ALIMENTAZIONE POWER	12 V _ 24 V
VELOCITÀ UP (PIENO CARICO) SPEED UP (FULL CHARGE)	5 M/MIN
VELOCITÀ DOWN (PIENO CARICO) SPEED DOWN (FULL CHARGE)	4 M/MIN

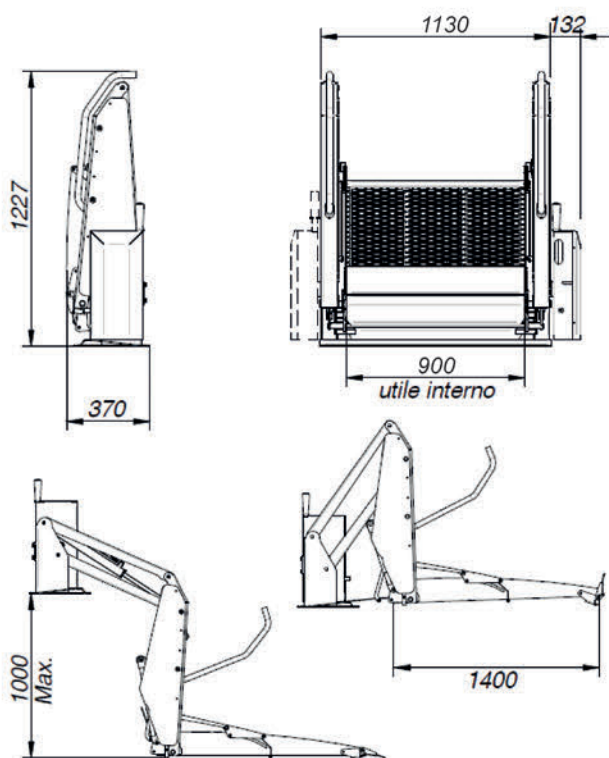

DISPOSITIVI DI SICUREZZA SAFETY DEVICES

- Interruttore stacca batteria con chiave.
Switch to detach battery with key.
- Funzionamento manuale delle operazioni in caso di emergenza.
Manual operation in case of emergency.
- Ribaltina automatica di sicurezza per blocco carrozzina.
Automatic safety ramp to stop the wheelchair.
- Ribaltina automatica di raccordo al veicolo.
Automatic safety ramp to connect to the vehicle.
- Dispositivo antiribaltamento con pressostato.
Roll-over control device with pressure switch.

Le sponde automatiche a doppio braccio sono state progettate e realizzate per veicoli gamma medio-alta abilitati al trasporto di persone.

The automatic double arm platforms have been conceived for medium-large vehicles which are suitable to transport people.

VEICOLI / VEHICLES:

Fiat Ducato, Iveco Daily, Mercedes Sprinter Kombi, Opel Movano, Renault Master, Volkswagen Crafter Kombi

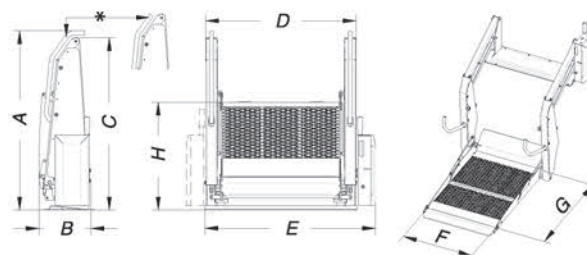

LIFT BBO	A	B	C	D	E	F	G
BBO 140.90	1227	370	1180	1130	1262	900	1400

INGOMBRI PEDANA BIBRACCIO ORIZZONTALE